

POWER CORD 2300 LONG OUTSIDE
(UK PLUG WITH EARTH WIRE)

COATING SHELF(627x607)

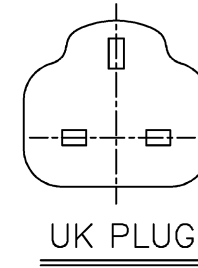

DIGITAL THERMOMETER

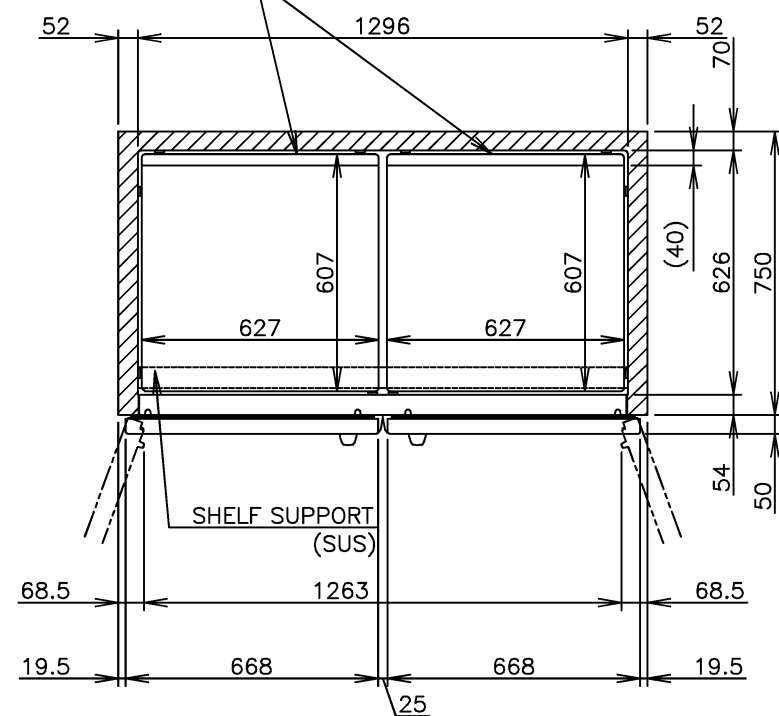
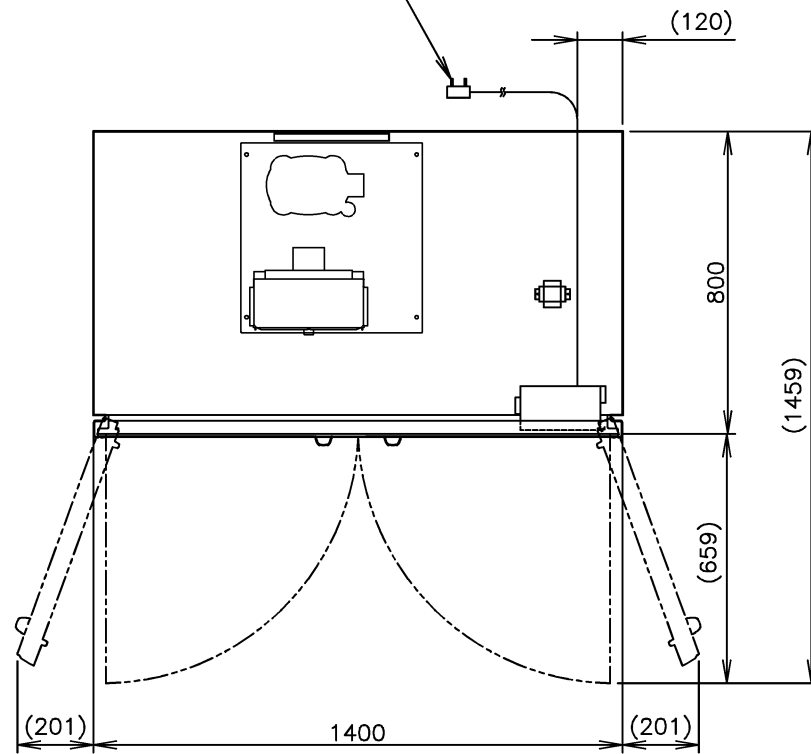
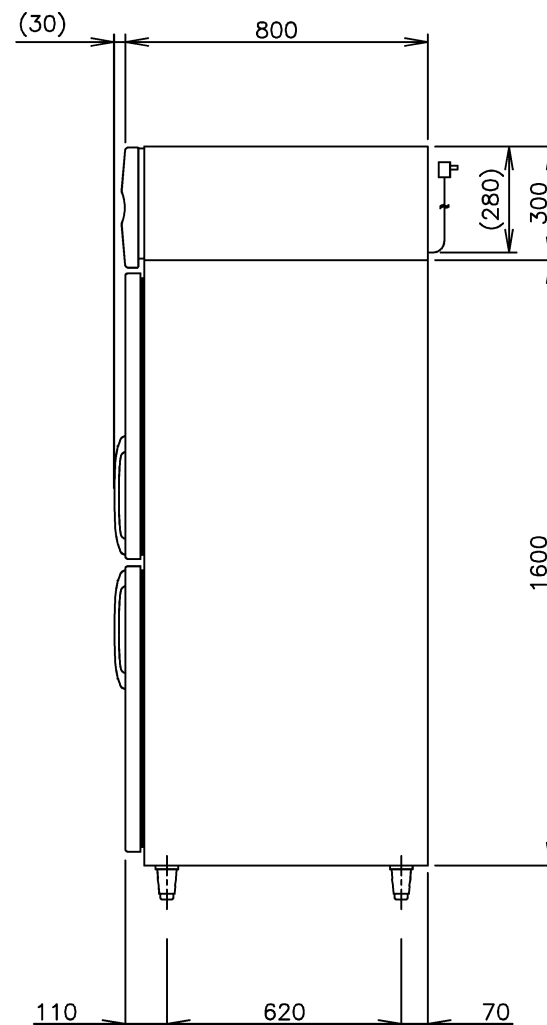
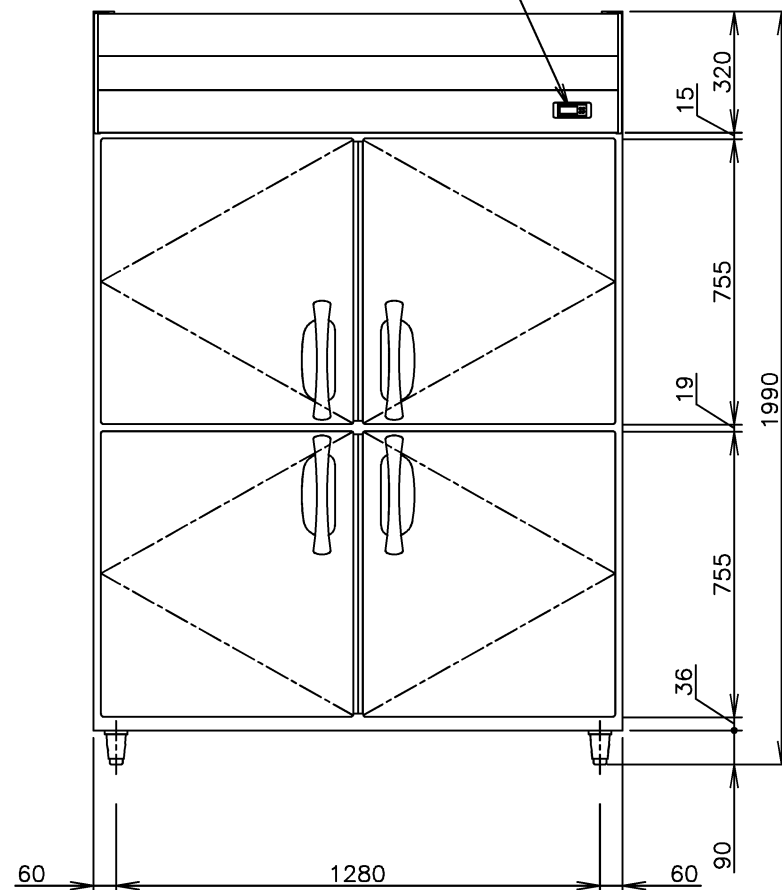

DRAIN EVAPORATING TANK

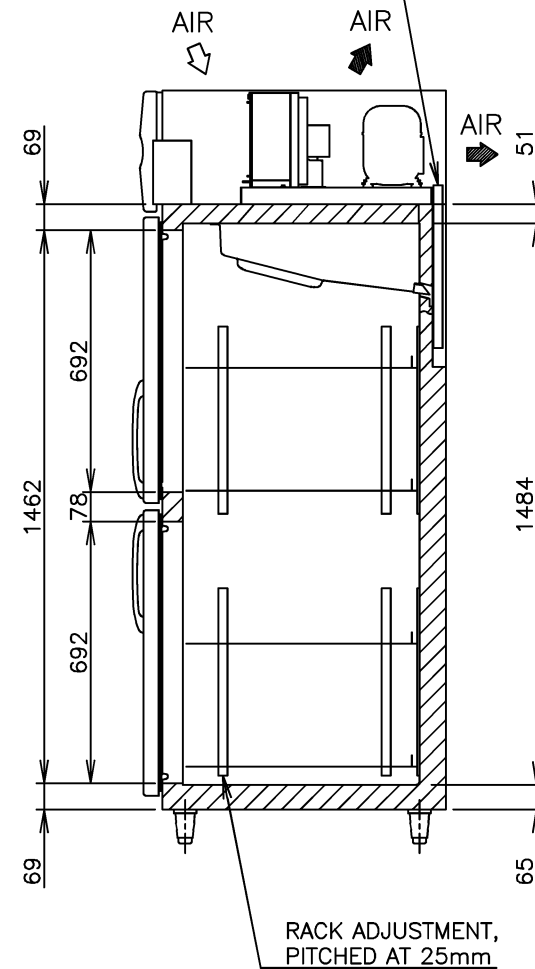

| | |
|--------------------------------|--|
| ITEM | Hoshizaki Reach-in Freezer |
| MODEL | HF-148MA-S-ML-J |
| POWER SUPPLY | 1 Phase 230V 50Hz |
| AMPERAGE | Rated: 6.0A |
| ELECTRIC CONSUMPTION | 926W Heater: 511W Defrost: 250W |
| POWER CORD | 2.3m (UK Plug with Earth Wire) |
| EFFECTIVE CAPACITY | 1243L |
| OUTSIDE DIMENSIONS | 1400mm(W)×800mm(D)×1990(-2020)mm(H) |
| INSIDE DIMENSIONS | 1296mm(W)×626mm(D)×1484mm(H) |
| EXTERIOR | Stainless Steel, Galvanized Steel(Top, Rear, Bottom) |
| INTERIOR | Stainless Steel, ABS Plastic(Door) |
| INSULATION | Polyurethane Foam |
| INSULATION FOAM BLOWING AGENT | Cyclopentane |
| REFRIGERATION SYSTEM | Forced Air Circulation |
| DEFROST SYSTEM | Heater |
| COMPRESSOR | Hermetic |
| CONDENSER | Wire and Tube type, Air-cooled |
| EVAPORATOR | Fin and Tube type |
| REFRIGERANT | R404A(300g) |
| TEMPERATURE CONTROL | Microprocessor (Digital Temp. Indication) Adjustable from -23 to -7℃ |
| DEFROST CONTROL | Microprocessor |
| ELECTRIC CIRCUIT PROTECTION | Earth Wire, Circuit Breaker |
| REFRIGERANT CIRCUIT PROTECTION | Motor Protector (Auto-reset) |
| LEG | Plastic Adjustable from 90 to 120mm |
| SHELF | 8 pcs. |
| WEIGHT | 163kg (Gross 193kg) |
| PACKAGE | Carton (Wooden Pallet) 1460mm(W)×900mm(D)×2075mm(H) |
| ACCESSORIES | SUPPORT SHELF × 4 |
| OPERATING CONDITIONS | Ambient Temperature: 5 - 43℃ Voltage Range: Rated Voltage ±6% |

*We reserve the right to make changes in specifications and design without prior notice.

1. Install the product properly in accordance with the instructions on location, water supply/drain connections and electrical connections stated in the instruction and installation manuals provided.
Allow 10mm extra space at the installation site to meet any installation requirements (additional spacing is also required for proper air flow and pipe connections).
2. The heat rejection is based on the reached pulldown temperature at ambient temperature of 35℃.
3. Product Code: R596-D119 (HK)

HOSHIZAKI REACH-IN FREEZER HF-148MA-S-ML-J

| | | | | | |
|--------------|------------|-------------|----------|-----------------|--------------------|
| APPROVED LYB | CHECKED WY | DESIGNED WY | DRAWN WX | SCALE 1/20 | TRIGONOMETRY |
| * | * | * | * | DATE 2021.03.05 | DRAWING NO. D30177 |
| APPROVED | DESIGNED | SYMBOL | DATE | | SYMBOL |