

1. Install the ice maker properly in accordance with the instructions on location, water supply/drain connections and electrical connections stated in the instruction and installation manuals provided. Allow 10mm extra space at the installation site to meet any installation requirements (additional spacing is also required for proper air flow and pipe connections).
2. The ice production depends on the ambient and water temperatures. Refer to the instruction manual.
3. The adjustable legs are optional. Consult with our sales staff.

* Customized
For Asia
Product Code: M087-D009

ITEM	Hoshizaki Big Ice Maker
MODEL	IM-55M-2-LM
POWER SUPPLY	1 Phase 220V 50Hz Capacity: 0.71kVA(3.3A)
AMPERAGE	Running: 1.6A Rated Motor: 1.6A Starting: 12A
ELECTRIC CONSUMPTION	265W (Power factor: 75%)
ICE PRODUCTION PER 24h	Approx. 32kg (AT.21°C, WT.15°C) Approx. 28kg (AT.32°C, WT.21°C)
SHAPE OF ICE	Big Ice Approx.48 x 48 x 58mm
ICE PRODUCTION PER CYCLE	Approx. 1.48kg/12 pcs.
MAX. STORAGE CAPACITY	Approx. 17kg (Unleveled: Approx. 8kg)
WATER CONSUMPTION PER 24h	Approx. 0.14m ³ (AT.21°C, WT.15°C) Approx. 0.13m ³ (AT.32°C, WT.21°C)
OUTSIDE DIMENSIONS	630mm(W) x 525mm(D) x 850mm(H)
HEAT REJECTION	690W
CABINET	Stainless Steel, Galvanized Steel (Rear) Fluorine-Coated Stainless Steel (Front panel,Door)
STORAGE BIN	Plastic, Insulation: Polyurethane Foam
INSULATION FOAM BLOWING AGENT	HFO-1233zd(E)
ICE MAKING SYSTEM	Cell Type, Jet Spray System
WATER SUPPLY SYSTEM	Direct Connection to Water Main, Inlet R1/2
DRAIN SYSTEM	Ice Making Water Drained Every Cycle, Outlet R3/4
COMPRESSOR	Hermetic 175W
CONDENSER	Fin and Tube Type, Air-cooled
EVAPORATOR	Tin-plated Copper Tube on Sheet and Cells
REFRIGERANT	R134a/240g
ICE MAKING CONTROL	Controller Board
HARVESTING CONTROL	Controller Board
BIN CONTROL	Double Lever (with Time Delay)
ICE MAKING WATER CONTROL	Controller Board
ELECTRIC CIRCUIT PROTECTION	Earth Leakage Circuit Breaker (with Overcurrent Protector)
REFRIGERANT CIRCUIT PROTECTION	Motor Protector
ICE MAKER PROTECTION	Shutdown by Microprocessor
NET WEIGHT	48kg(Gross 52kg)
PACKAGE	Carton 748(W) x 629(D) x 915(H)mm
ACCESSORIES	Scoop, Adjust Bolt, Inlet Hose, Outlet Hose, Reducing Joint
OPTIONAL PARTS	Adjustable Legs, Strainer
OPERATING CONDITIONS	Ambient Temp.: 5 - 38°C, Water Supply Pressure: 0.05 - 0.78MPa Voltage Range: Rated Voltage ±10%

*We reserve the right to make changes in specifications and design without prior notice.

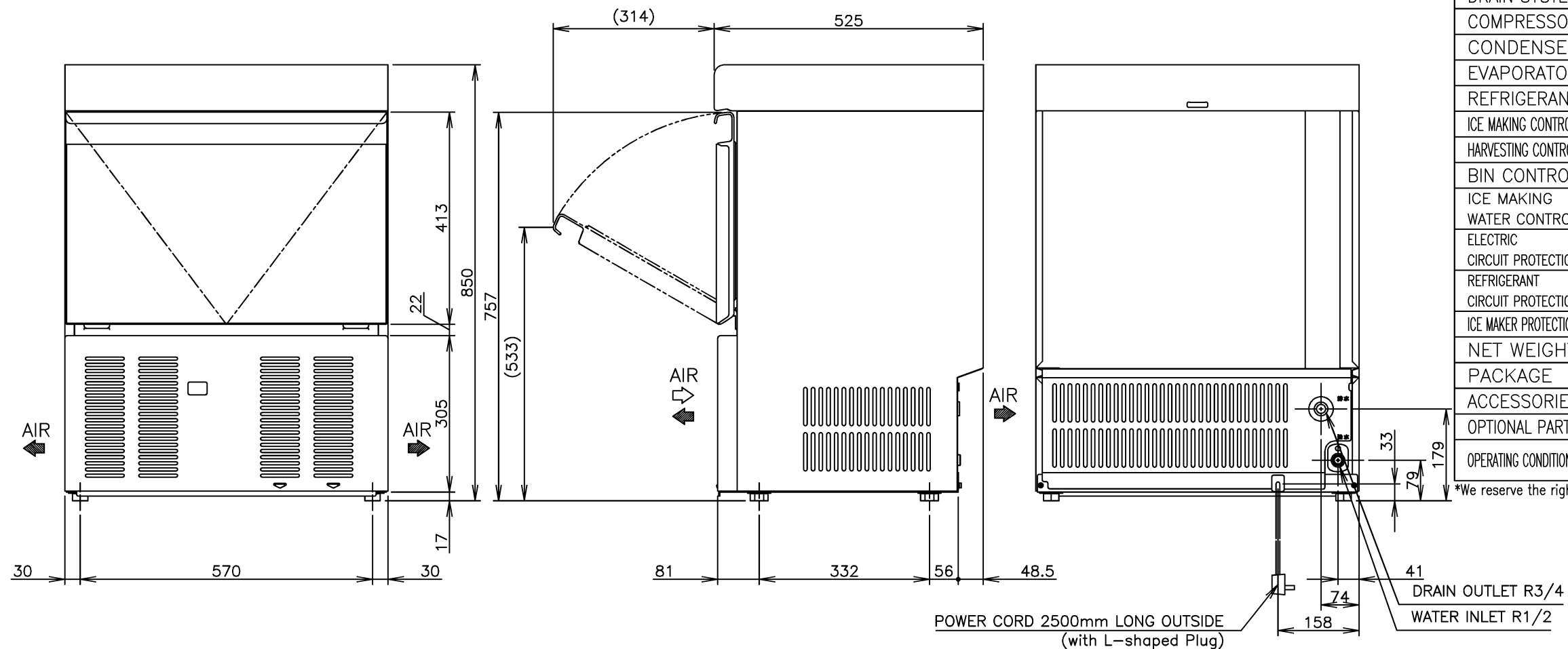

HOSHIZAKI BIG ICE MAKER IM-55M-2-LM

APPROVED YAMASAKI	CHECKED S.NOTSU	DESIGNED A.NAGASAWA	DRAWN OHASHI	SCALE 1/10	TRIGONOMETRY
YAMASAKI	TOMINAGA	2021.02.18	DATE 2020.07.10	DRAWING NO. D28717	SYMBOL 3
APPROVED	DESIGNED	SYMBOL	DATE		