

VIEW A

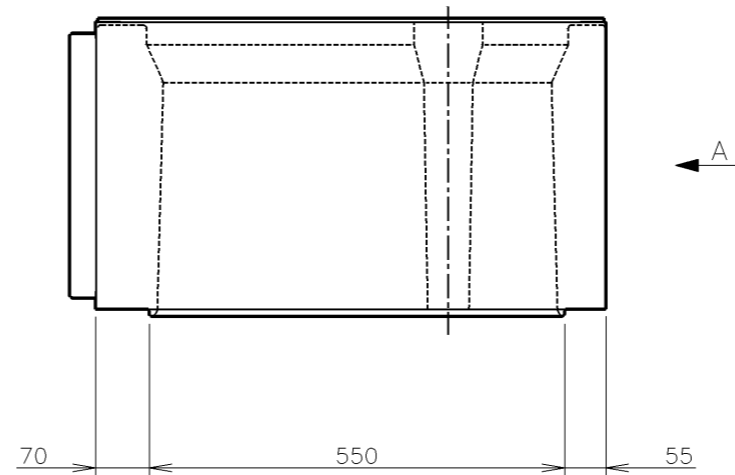

ITEM	HOSHIZAKI SLEEVE
MODEL	N-200A
MAX. STORAGE CAPACITY	Approx. 95kg Cube Ice・Cubelet Ice
OUTSIDE DIMENSIONS	1080mm(W)×710mm(D)×385mm(H)
INSIDE DIMENSIONS	976mm(W)×558mm(D)×395mm(H)
EXTERIOR	Stainless Steel, Galvanized Steel (Rear) Fluorine Coated Stainless Steel (Front)
INTERIOR	PE Plastic(Blue)
INSULATION	Polyurethane Foam
DRAIN SYSTEM	φ23(OD)
WEIGHT	24kg (Gross 30kg)
PACKAGE	Carton 1160mm(W) x 750mm(D) x 410mm(H)
ACCESSORIES	Drain Pipe, Gasket

Based on Specs. No.99021

1. Install the product properly in accordance with the instructions on location, water supply/drain connections and electrical connections stated in the instruction and installation manuals provided.